

StrapPack[®]

High Speed Paper/Film Tape Banding Machine

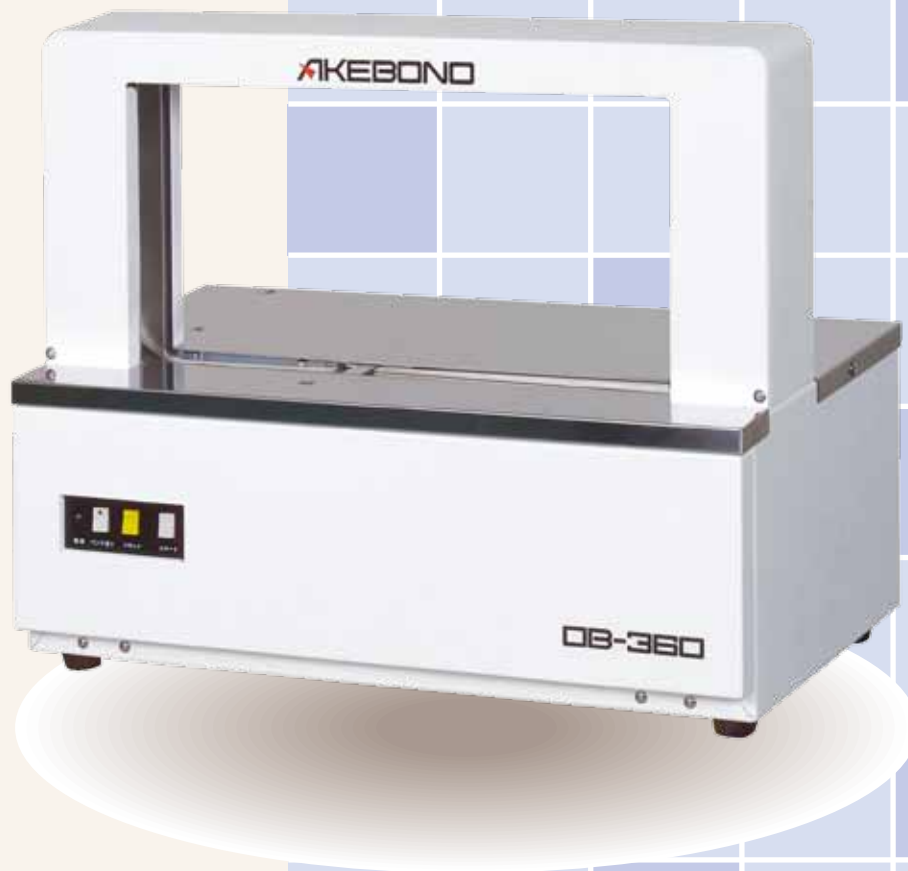

OB-360

OB-360



High Speed Paper/Film Tape Banding Machine

■ High Speed

Up to 30 cycles per minute. Soft or elastic bundles can be banded without sacrificing the speed.

■ Versatile

-Applies banding to packages as small as 30mm (1-1/8") wide x 10mm (3/8") high up to 480mm (16-1/2") wide x 210mm (8-1/4") high.

-Either paper or film tape can be used.

-The new track design allows the use of 60 micron thick film, reducing cost and waste.

■ Adjustable Tension

Tension is adjustable from 5N to 30N (approx. 1 - 6.6lbsf).

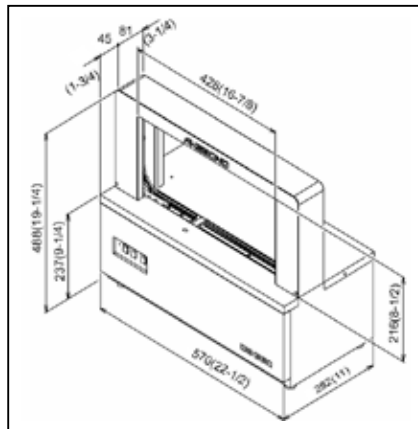

■ Friendly Operation

- A cycle can be actuated by simply placing a bundle on the table, pressing the Start button or stepping on the foot pedal.

-“Pause Mode” can be selected to leave the track open until the package is removed from the table, helping to eliminate the biting or tearing of the tape in certain applications.

■ Good Sealing

Improved sealing/heater design helps achieve an even melting and seamless seal eliminating curled, folded or peeling tape edges.



Large dispenser stand is available upon request.

■ Standard Specifications

Arch Size		W420x210H	W16-1/2 X H 8-1/4 in.
Dimension	Width	570 mm	22-1/2 in.
	Height	488 mm	19-1/4 in.
	Depth	282 mm	11-1/8 in.
	Weight	25.5 kg.	56 lbs.
Table Height		237 mm	9-1/4 in.
Min. Package Size		W 30 X H 10 mm	W 1-1/8 X H 3/8 in.
Max. Package Size		W420 X H 210 mm	W16-1/2 X H 8-1/4 in.
Tape		W 30 mm x 190m 80g (paper) W30mm x 200-370m 60-110µm (film)	W 1-1/8 in x 623ft 28 ounce (paper) W1-1/8 in x 656-1214ft 60-110µm (film)
Strap Tension		5-30N (0.5-3kgf) adjustable	1 - 6.6 lbsf (adjustable)
Power Supply		100-120, 200-240 V	1 Phase 50 / 60 Hz

Dimensions and specifications are subject to change without notice.

Modification rights reserved.

Pats., U.M. & design registered and/or pending.

© 2011 Strapack Corporation

DISTRIBUTED BY:

STRAPACK CORPORATION

7-16-14, Ginza, Chuo-ku Tokyo 104-0061, JAPAN
Phone 81-3-6278-1805 Fax. 81-3-6278-1806
(URL) <http://www.strapack.com> (E-mail) info@strapack.com

STRAPACK INC.

30860 San Clemente St. Hayward, CA 94544 U.S.A.
Phone 1-510-475-6000 Fax. 1-510-475-6090

STRAPACK, N.V./S.A.

Uilenbaan 200, 2160 Wommelgen, BELGIUM
Phone 32-3-355-1520 Fax. 32-3-355-1521